

Q1. What are a manipulator, wrist and end effectors for a robot? Why has the wire EDM process become so widely accepted in industry?

[IES 2010; 5 Marks]

Ans. Manipulator: - Manipulator are built as series chains or parallel chains or occasionally a combination of both. Links and joints (revolute and prismatic) that are mostly used in manipulators. In spatial manipulators (open chains) adjacent axes are parallel or perpendicular to each other.

Wrists: - Wrists roll, yaw and pitch. There are 3 motions and 3 actuators are required for motion.

End effectors: - continuous path motion – painting application are an example when the end effector has to move over a desired curve in space. The robot end effector is required to reach the centre of circle the target point. The circle on extreme left shows the situation when the robot has poor accuracy and poor repeatability. The circle in the middle shows the EE had been repeatedly reaching positions which are closely together through way from the target point.

Wire EDM :- Electric discharge wire cutting or more commonly called wire EDM is a process of producing complex two and three dimensional shapes using a simple wire ending the material from a electrically conducting material, wire EDM is used for matching sheet metal dies/extrusion dies and proto type part it is relatively a very slow process (line travels of the order of 100 m/hr 25 mm thick sheet utilizing computer controlled machines, that's why wire EDM is widely accepted in industry.

Q2. In FMS define the terms : Automatic Guided Vehicle (AGV) and DNC. Explain the terms chucking reamers and climb milling. What effect does the helix angle have on drill performance. Explain the terms combined cuts and multiple cuts.

[IES 2010; 15 Marks]

Ans. Automatic guided vehicle (AGV) :- It is mobile robot that follows markers or wire in the floor or uses vision or lasers. They are most often used in industrial application to move material around a manufacturing facility or a warehouses. AGV system lareliable horizontal transportation when spacels at a premium and flexibility is critical e.g Aerospace, Automotive, clean room.

Direct numerical control (DNC):- It is commonly manufacturing term for networking CNC machine tool. On some CNC machine controllers the available memory is too small to contain the machine programmed. So in this case the programme is stored in separate computer and sent directly to the machine. If the computer connected to a number of machines it can distribute programme to different machine required. DNC networking or DNC communication is always required when CAM programme are run or some CNC machine control.

Helix angle effect:- An increase in the helix angle to more quickly remove chips but a decrease in helix angle in the interest of greater strength of cutting edges, in the drilling performance.

Q3. Expand the following :

[IES 2010; 10 Marks]

- (i) ASCII
- (ii) BCD
- (iii) MDI
- (iv) RAM

(v) ROM

Ans. ASCII – American standard code for information interchange
 BCD – binary code decimal
 MDI – multiple document interface
 RAM – random access memory
 ROM – read only memory

Q4. What is the function of manipulator in a robot? Classify robots as per their path control. [IES 2008; 2 Marks]

Ans. The function of manipulator in a robot is to permit relative motion with certain degree of freedom. Robots are classified on the basis of their path of control as:

- (i) **Point to point (PTP):** Point to point programming causes the robot to shift from a programmed point to next programmed point, with a pause between each movement.
- (ii) **Continuous path:** Continuous path programming causes the robot to move in a smooth continuous manner along a defined trajectory.

Q5. Name the four types of statements in a complete APT part program. Prepare part program for geometry description of the contour shown in the figure below: [IES-2008, 15-Marks]

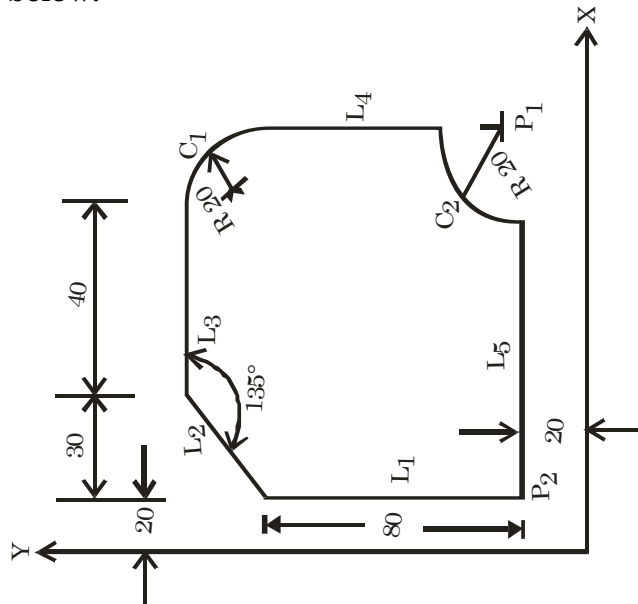

Ans. Four types of statements in complete APT part program are given below.

- (i) Motion statement – describes the path of cutting tool
- (ii) Geometry statement- describes configuration of surface
- (iii) Post Processor Statement-function of particular machine tool
- (iv) Auxiliary Statement – that aren't covered by the above three statements.

Program in APT
 PARTNO CONTOUR
 MACHIN/MILL, 1
 CLPRNT

UNITS/MM

P0 = POINT/0.0, 0.0, 0.0

P1 = POINT/110.0, 20.0, 0.0

P2 = POINT/20.0, 20.0, 0.0

P3 = POINT/90.0, 110.0, 0.0

P4 = POINT/20.0, 100.0, 0.0

P5 = POINT/50.0, 130.0, 0.0

L1 = LINE/P2, ATANGL, 90, XAXIS

L2 = LINE/P4, ANTANGL, 45, XAXIS

L3 = LINE/P5, ATANGL, 135, L2

L4 = LINE/P1, PERPTO, L3

L5 = LINE/P1, PERPTO, L4

C1=CIRCLE/CENTER, P3, RADIUS, 20.0

C2=CIRCLE/CENTER, P1, RADIUS, 20.0

PL1=PLANE/P1, P2, P3

CUTTER/10.0

TOLER/0.1

INTOL/0.005

OUTTOL/0.005

SPINDL/500, CLW

COOLNT/ON

FEDRAT/200

FROM/P0

GO/TO, L1, TO, PL1, TO, L5

GOLFT/L1, PAST, L2

GORGTL2, PAST, L3

GORGTL3, PAST, C1

GORGTC1, PAST, L4

GORGTL4, PAST, C2

GORGTC2, PAST, L5

GORGTL5, PAST, L1

RAPID

GOTO/P0

COOLNT/OFF

SPINDL/OFF

END

FINI

Q6. State any four basic elements of a Robot. Give one line statement for each.

[IES 2007; 2 Marks]

Ans. The vast majority of today's commercially available robots possess one of the four basic configurations

- (i) Polar configuration
- (ii) Cylindrical configuration
- (iii) Cartesian coordinate configuration
- (iv) Jointed arm configuration

The four basic configurations are illustrated in the schematic diagrams of figure.(i) (a to d)

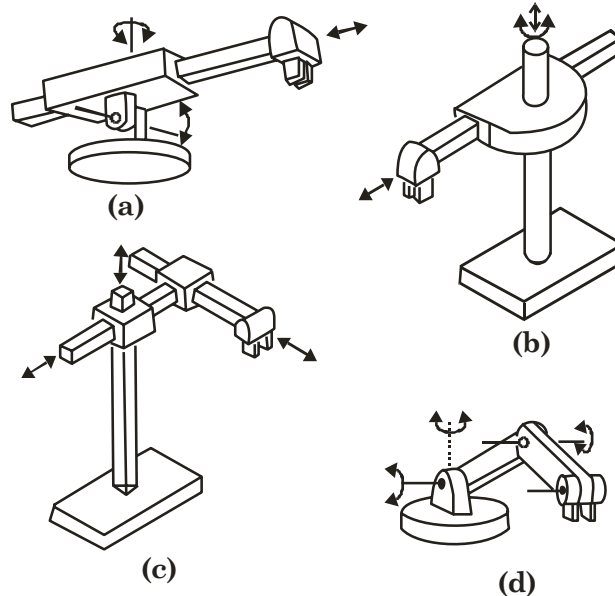

Figure (i) (a): Polar configuration uses a telescopic arm that can be raised or lowered about a horizontal pivot. The pivot is mounted on a rotating base. These various joints provide the robot with capacity to move its arm within a spherical space, and hence its name spherical coordinate robot.

Figure (i) (b): Uses a vertical column and a slide that can be moved up or down along the column. The robot arm is attached to the slide so that it can be moved radially with respect to the column. By rotating the column, the robot is capable of achieving a work space that approximates a cylinder.

Figure (i) (c): Uses three perpendicular slides to construct the x, y and z-axes. By moving the three slides relative to one another, the robot is capable of working in a rectangular work envelope.

Figure (i) (d): Its configuration is similar to that of the human arm. It consists of two straight components corresponding to the human forearm and upper arm mounted on a vertical pedestal. These components are connected by two rotary joints corresponding to the shoulder and elbow. A wrist is attached to the end of the forearm, thus providing several additional joints.

Q7. Prepare part using APT language for milling the contour shown in Fig. in

a single pass.

[IES-2007, 20-Marks]

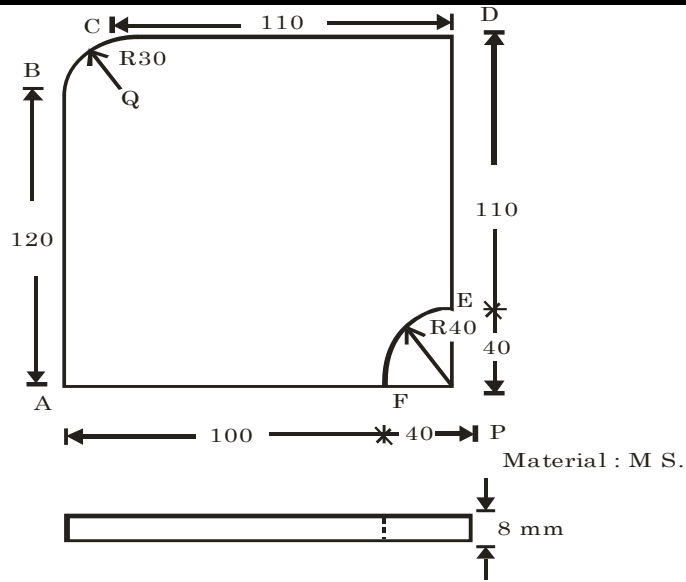

Answer:

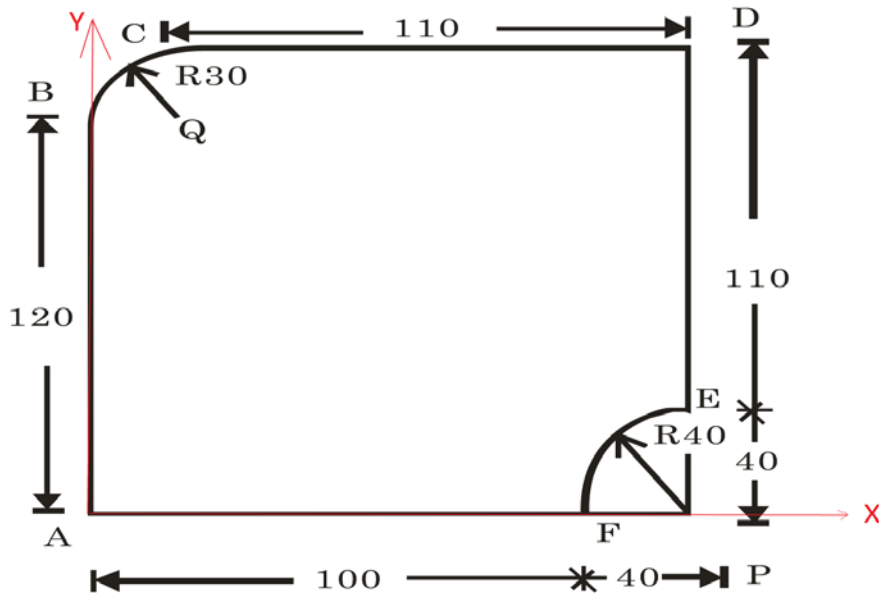

PARTNO CONTOUR

MACHIN/MILL, 2

CLPRNT

UNITS/MM

P0 = POINT/0.0, 0.0, 10.0

PTA = POINT/0.0, 0.0, 0.0

PTB = POINT/0.0, 120.0, 0.0

PTC = POINT/30.0, 150.0, 0.0

PTD = POINT/140.0, 150.0, 0.0

PTE = POINT/140.0, 40.0, 0.0

PTF = POINT/100.0, 0.0, 0.0

PTQ = POINT/30.0, 120.0, 0.0

PTP = POINT/140.0, 0.0, 0.0

LAB = LINE/PTA, PTB

LCD = LINE/PTC, PTD

LDE = LINE/PTD, PTE

LAF = LINE/PTA, PTF

CBC = CIRCLE/CENTRE, PTQ, RADIUS, 30.0

CEF = CIRCLE/CENTRE, PTP, RADIUS, 40.0

PL1=PLANE/PTA, PTB, PTC

CUTTER/10.0

TOLER/0.1

INTOL/0.005

OUTTOL/0.005

SPINDL/500, CLW

COOLNT/ON

FEDRAT/200

FROM/P0

GODOWN/0.0, 0.0, -8.0

GO/TO, LAB, TO, PL1, TO, LAF

GO/TO, LAB, PAST, CBC

GORGT/CBC, PAST, LCD

GORGT/LCD, PAST, LDE

GORGT/LDE, PAST, CEF

GORGT/CEF, PAST, LAF

GORGT/LAF, PAST, LAB

RAPID

GOTO/P0

COOLNT/OFF

SPINDL/OFF

END

FINI

- Q8. Prepare part program to machine the contour shown in the figure using APT on CNC milling machine. [IES-2006, 15-Marks]

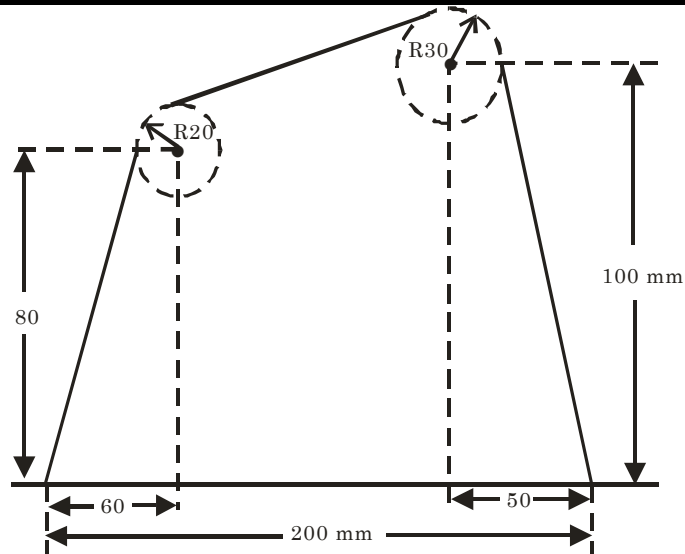

Material: MS
Thickness: 8.0 mm

Answer:

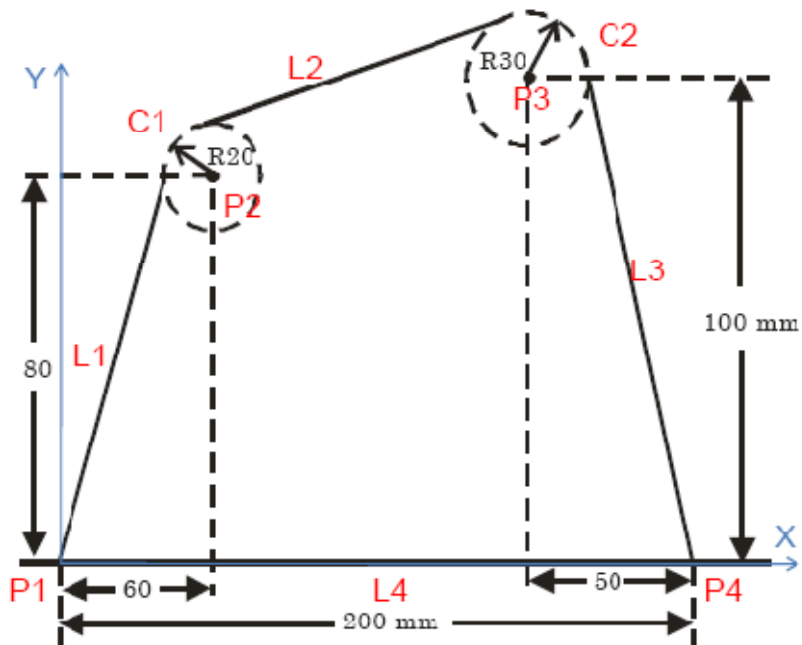

PARTNO CONTOUR

MACHIN/MILL, 3

CLPRNT

UNITS/MM

P0 = POINT/0.0, 0.0, 10.0

P1 = POINT/0.0, 0.0, 0.0

P2 = POINT/60.0, 80.0, 0.0

P3 = POINT/150.0, 100.0, 0.0

P4 = POINT/200.0, 0.0, 0.0

C1 = CIRCLE/ CENTRE, P2, RADIUS, 20

C2 = CIRCLE/CENTRE, P3, RADIUS, 30

L1 = LINE/P1, LEFT, TANTO, C1

L2 = LINE/RIGHT, TANTO, C1, RIGHT, TANTO, C2

L3 = LINE/P4, RIGHT, TANTO, C2

L4 = LINE/P1, P4

PL1=PLANE/P1, P2, P3

CUTTER/10.0

TOLER/0.1

INTOL/0.005

OUTTOL/0.005

SPINDL/500, CLW

COOLNT/ON

FEDRAT/200

FROM/P0

GODOWN/0.0, 0.0, -8.0

GO/TO, L1, TO, PL1, TO, L4

GO/TO, L1, PAST, C1

GORGTC1, PAST, L2

GORGTL2, PAST, C2

GORGTC2, PAST, L3

GORGL3, PAST, L4

GORGL4, PAST, L1

RAPID

GOTO/P0

COOLNT/OFF

SPINDL/OFF

END

FINI